

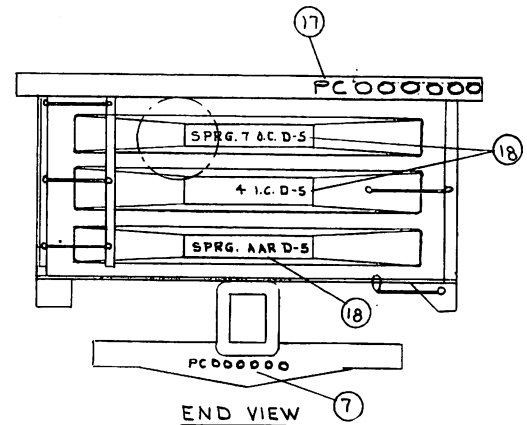

ADD NEW 1/8" PLATE TO EXISTING PLATE  
RIVET & WELD.

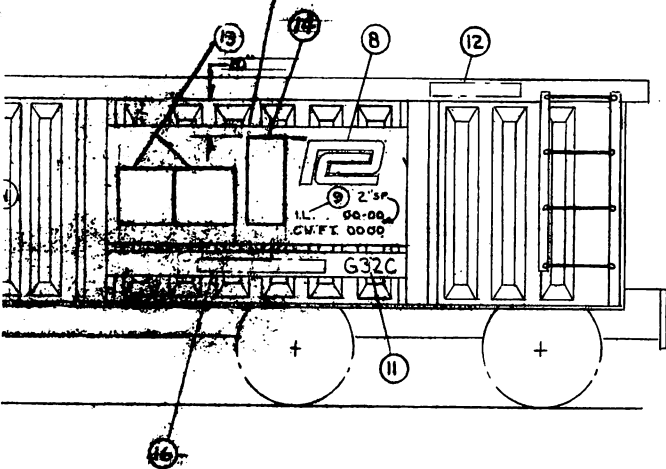

IF FLOORS ARE GIVEN THE  
D AND STEEL FLOORS ARE  
EL FLOORING THE SYMBOL (NS)  
SOL AT ALL.  
AS LISTED IN AAR MANUAL OF  
NON-STANDARD SPRING GROUP,

STANDARD ALPHABETS & NUMERALS	
SIZE	DRAWING NO
1"	E-454667
1 1/2"	D-454668
2"	D-454179
3"	C-454166
4"	C-454161
9"	A-464104
COLOR SCHEME	
1	SIDES & ENDS - EXTERIOR: PENN CENTRAL GREEN
2	UNDERFRAME: BLACK
3	FLOORS, SIDES & ENDS - INTERIOR: NOT PAINTED
4	STENCILING: WHITE

C	DRAWING REFERENCE FOR ITEM 13 WAS A-466456 (11-19-74) DEL
B	DRAWING REFERENCE ITEM NO. 13 WAS E-466231 3-1-74 (F-2-74)
A	5-15-73 (F-2-73)
LETTER	ISSUE

CLASS- G 32 C

**PENN CENTRAL**  
PHILADELPHIA, PENNSYLVANIA

**FREIGHT CARS  
STENCILING  
ARRANGEMENT**

D		466404		DIRECTOR-EQUIP. ENG	
DR.	CH.	CHK.	DATE	BY	DATE
GLP	JRR	AB			3-15-73